

Assembly Instructions for Servo-Driven Gear Rack Kit (Dual Gear Rack)

SKU: 3207-0001-0002

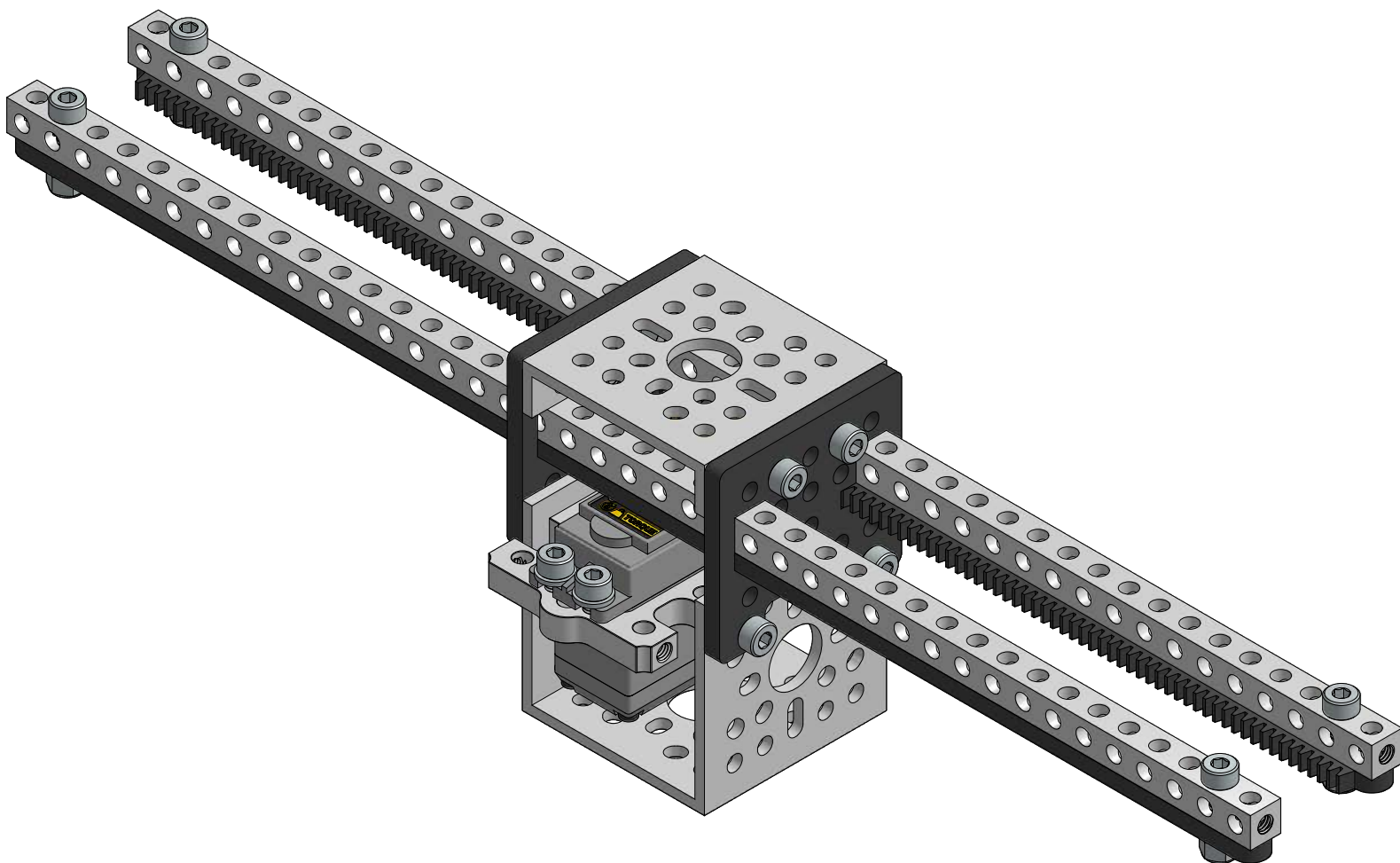

TOOLS REQUIRED

- 2.5mm Hex Key (L-Key or T-Handle)
- 3mm Hex Key (L-Key or T-Handle)
- 7mm Nut Driver

Kit Contents:

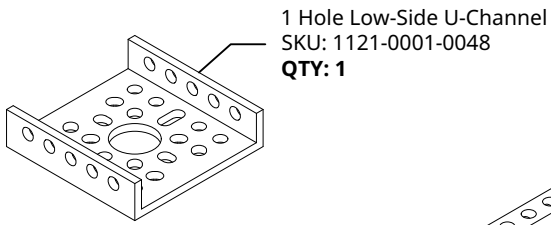

1 Hole Low-Side U-Channel
SKU: 1121-0001-0048
QTY: 1

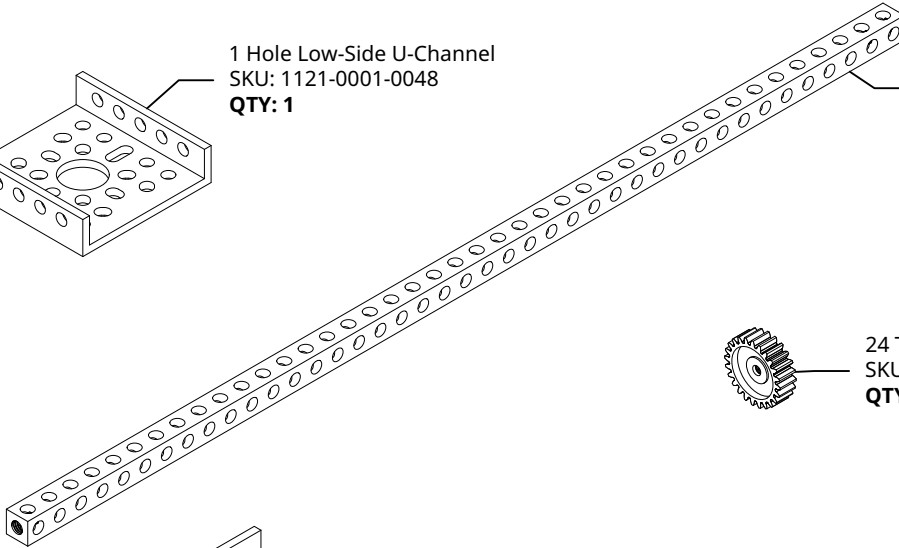

41 Hole Square Beam
SKU: 1106-0041-0328
QTY: 2



24 Tooth Servo Gear (H25T Spline)
SKU: 2305-0025-0024
QTY: 1

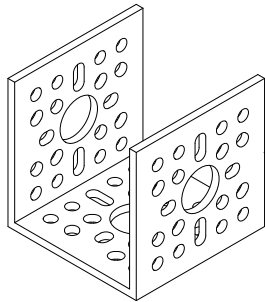

1 Hole U-Channel
SKU: 1120-0001-0048
QTY: 1

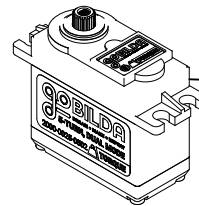

goBILDA 5-Turn Servo (Torque)
SKU: 2000-0025-0502
QTY: 1

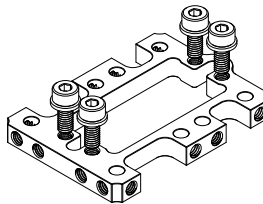

Servo Frame
SKU: 1802-0043-0001
QTY: 1



Servo Screw
Included with Servo

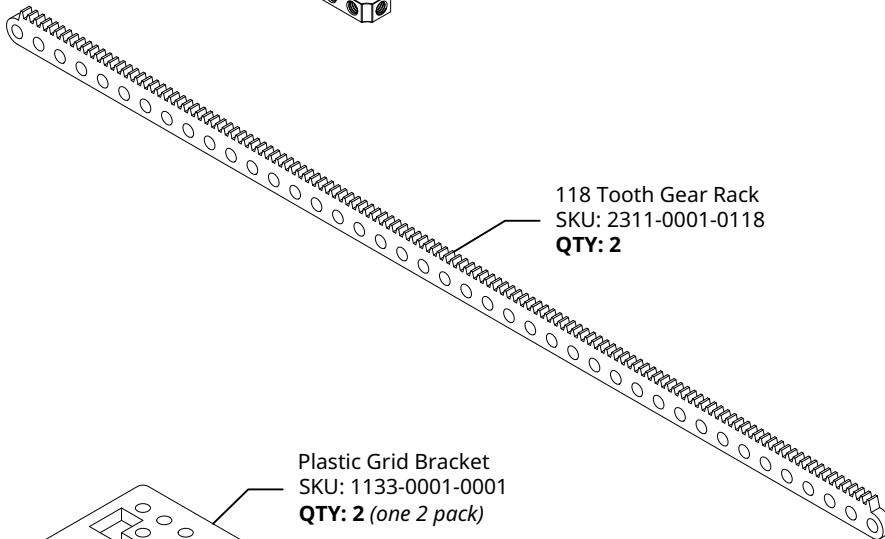

118 Tooth Gear Rack
SKU: 2311-0001-0118
QTY: 2

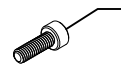

12mm Length M4 Screw
SKU: 2800-0004-0012
QTY: 25 (one 25 pack)

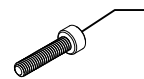

18mm Length M4 Screw
SKU: 2800-0004-0018
QTY: 25 (one 25 pack)

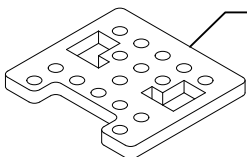

Plastic Grid Bracket
SKU: 1133-0001-0001
QTY: 2 (one 2 pack)



M4 Locknut
SKU: 2812-0004-0007
QTY: 25 (one 25 pack)

Step 1

Attach the servo frame to the servo using the four screws and washers that were included with the servo frame. Then attach the servo gear to the servo spline using the servo screw.

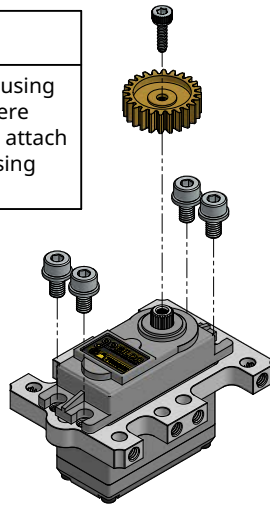

Step 2

Using four 12mm length screws and four locknuts, attach the plastic brackets to the 1-hole Low-Side U-Channel.

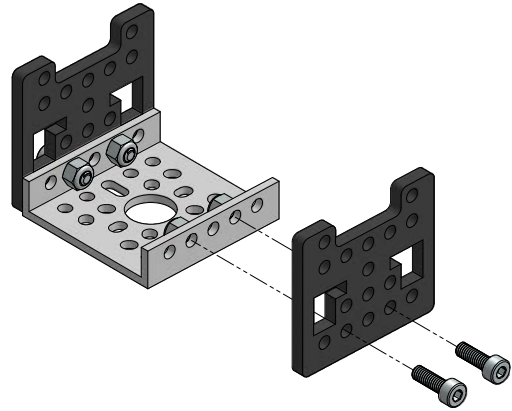

Step 3

Use one 18mm length screw and one locknut per gear rack to attach the gear racks to the beams.

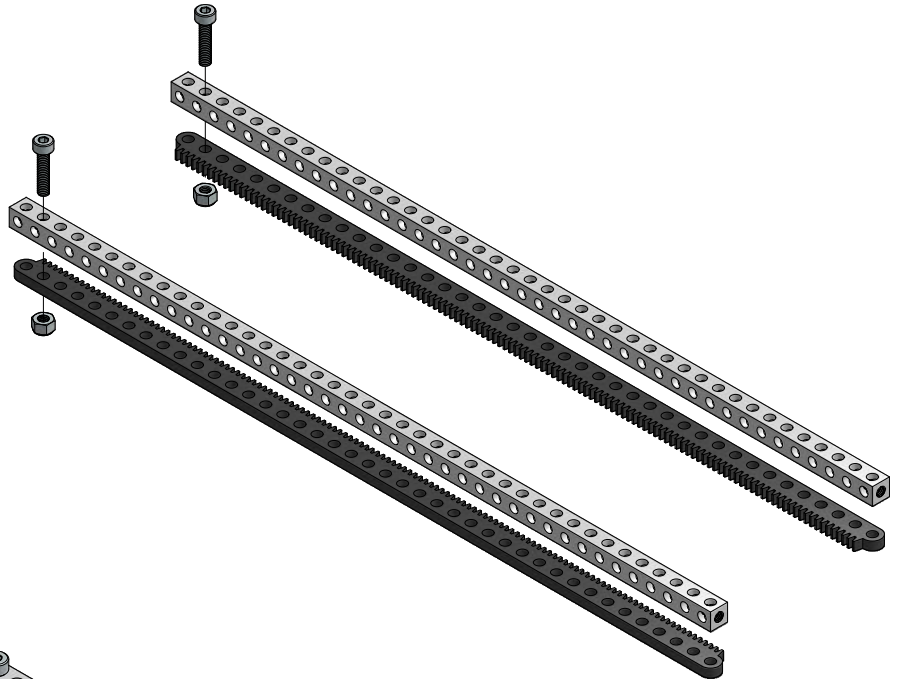

Step 4

Slide the gear rack assemblies through the passageways of the plastic brackets. Insert another 18mm length screw and nut on the other side of each.

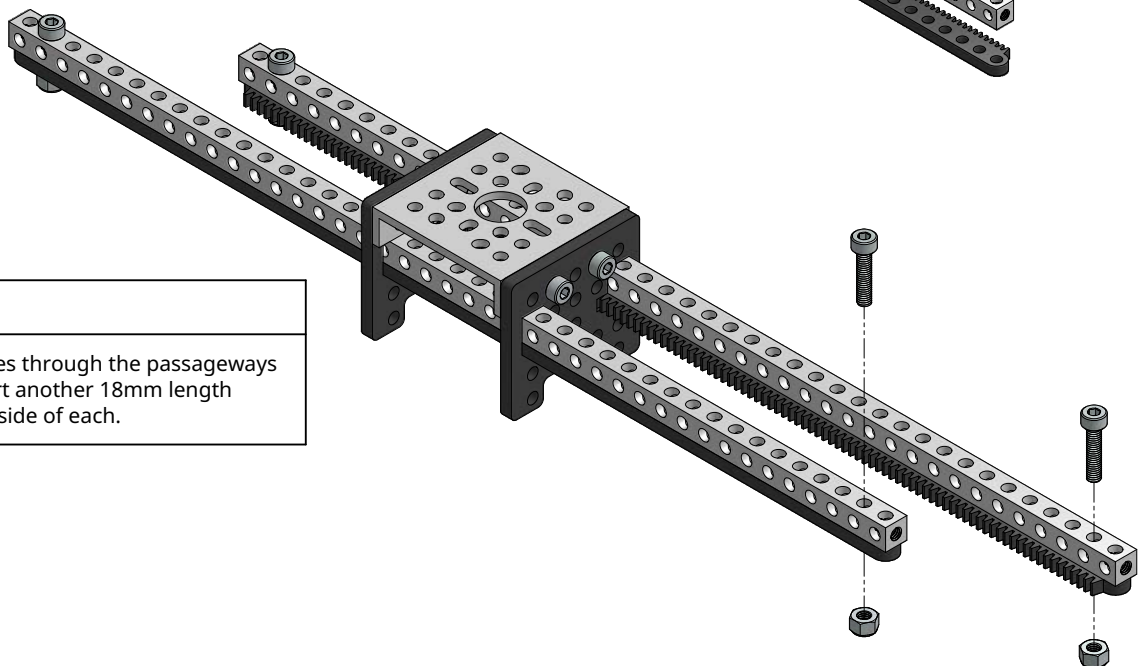

Step 5

Center both gear racks. Four extra screws can be inserted into the beams where shown to help keep them centered.

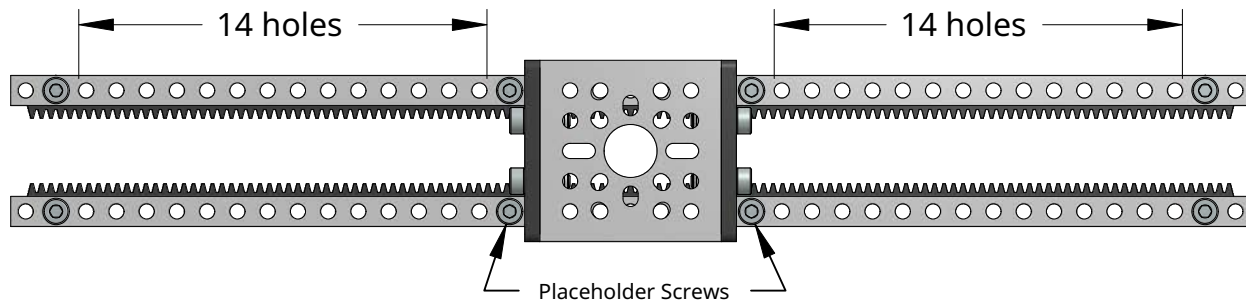

Step 6

Plug the servo into your servo controller and center the servo. Unplug the servo.

Assemble the 1-Hole U-Channel with your previously built assemblies - use four 12mm length screws to fasten it all together.

Remove the placeholder screws.

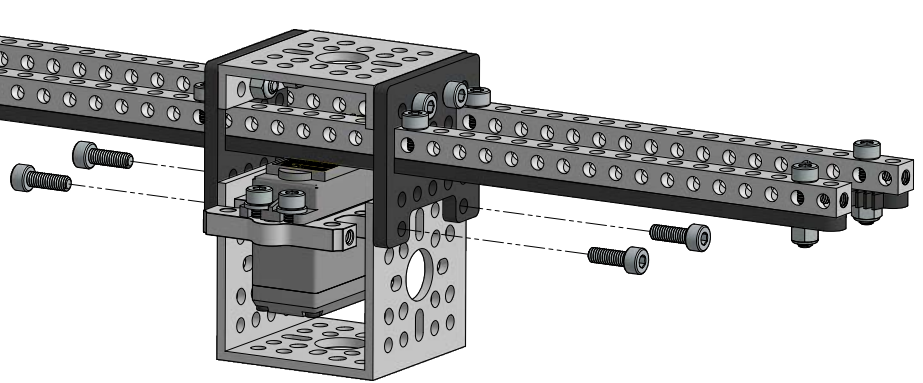

Congratulations!

You are now ready to plug your servo back in and test out your new gear rack kit!

