

Assembly Instructions for
Recon Chassis
SKU: 3209-0004-0001

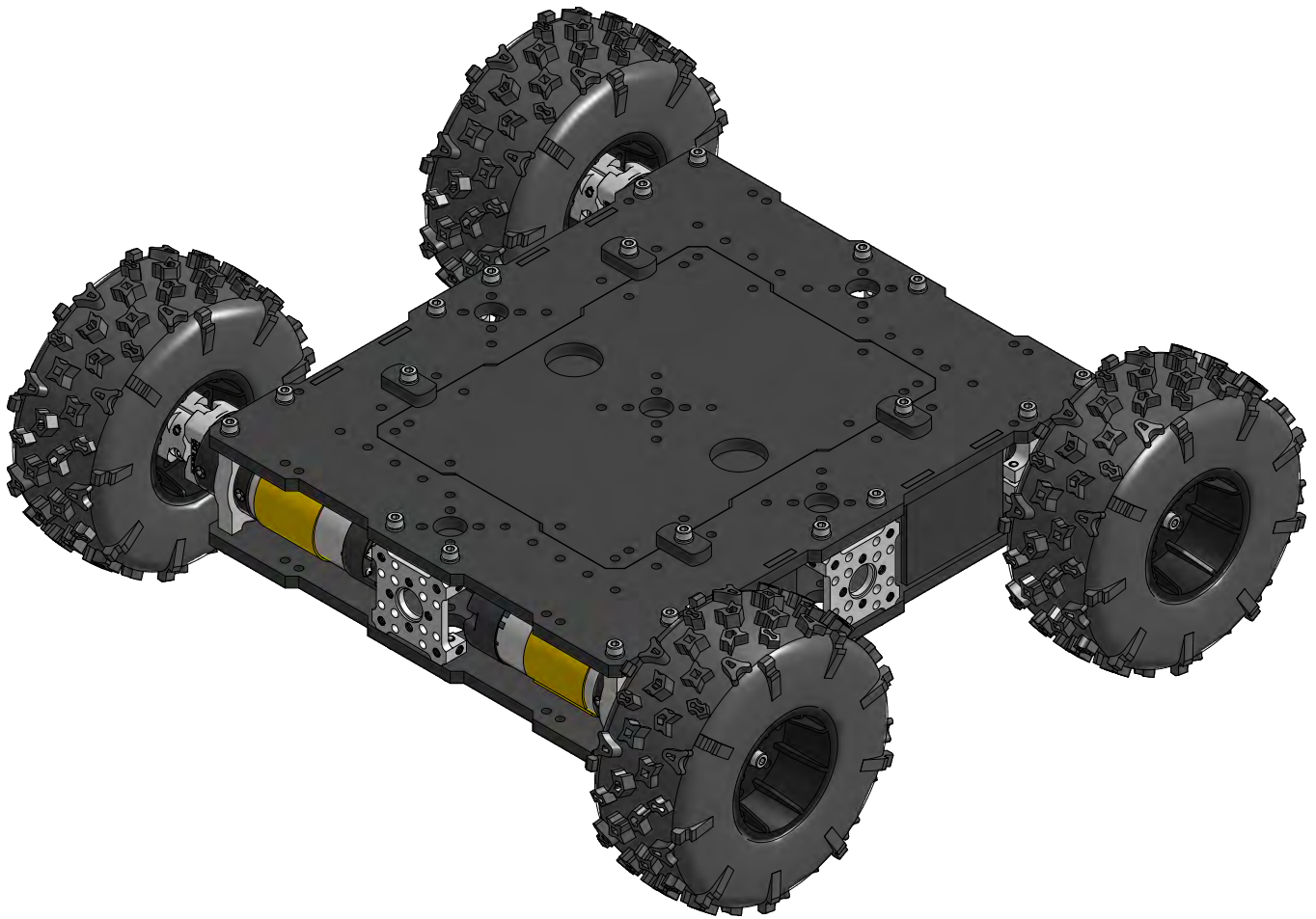

Visual BoM

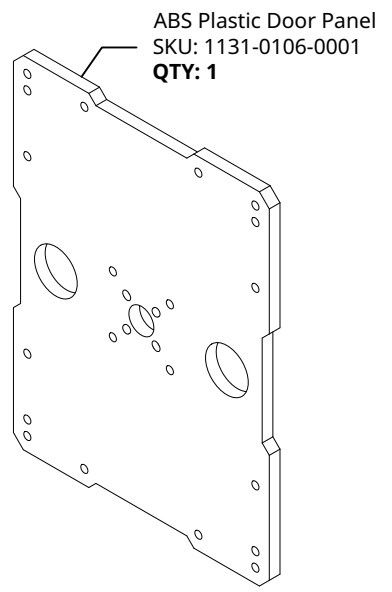
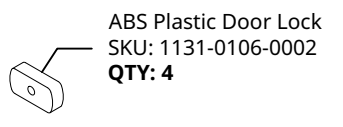
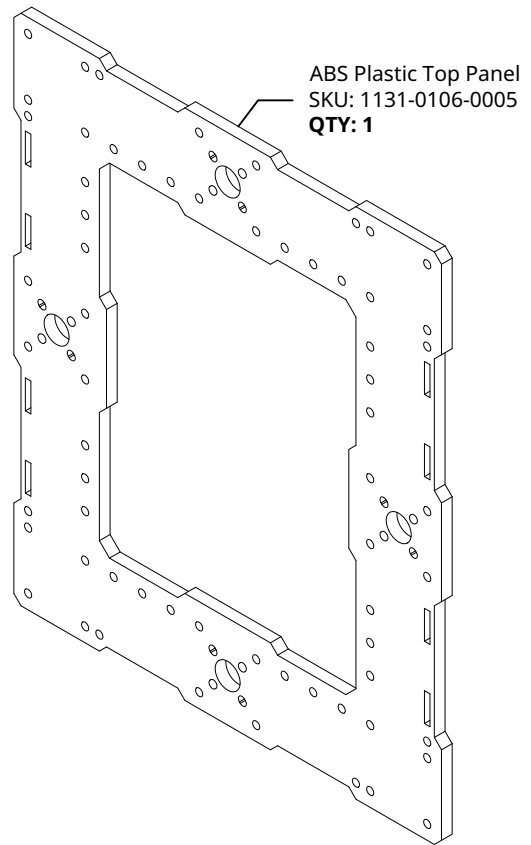
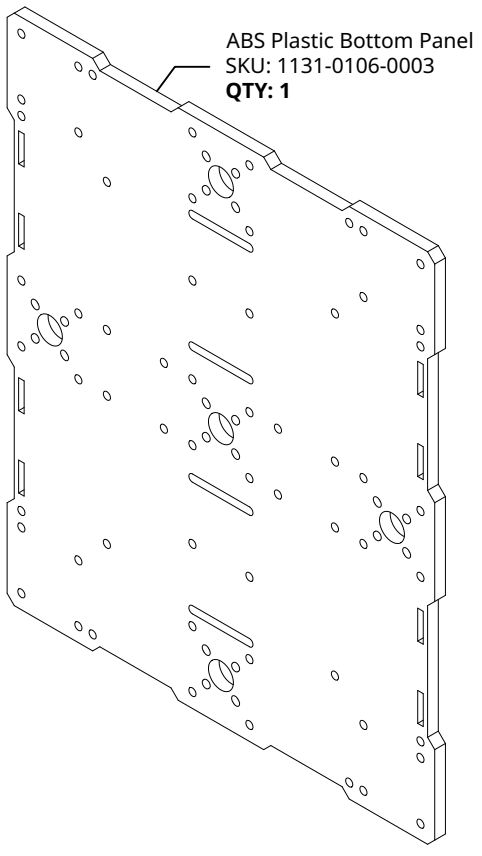
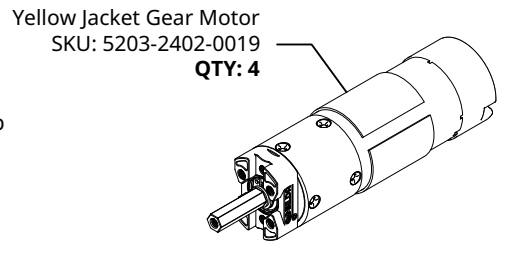
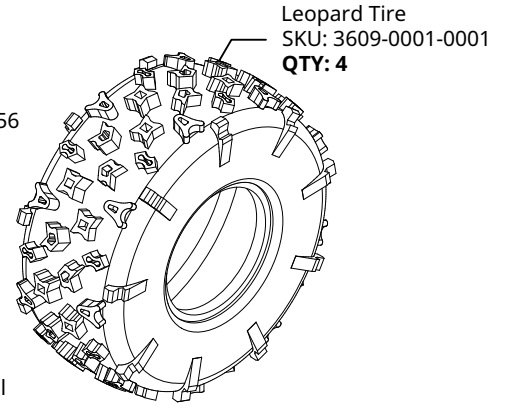
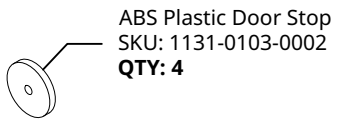
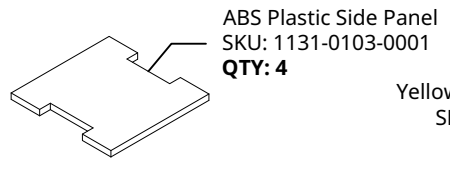
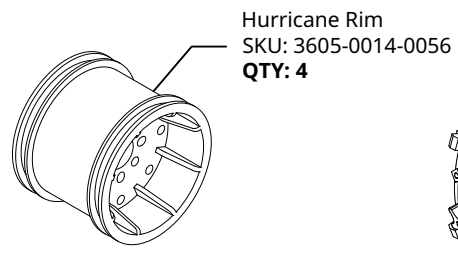
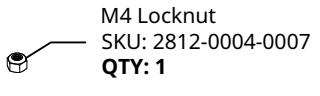
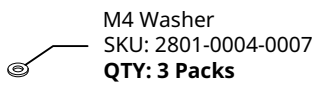
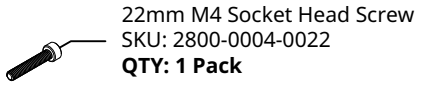
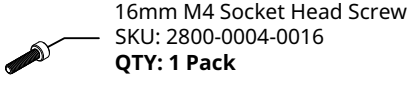
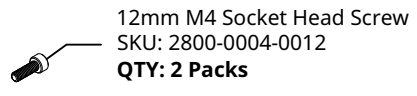
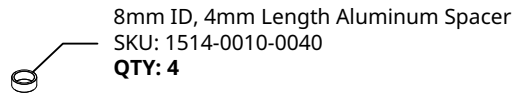
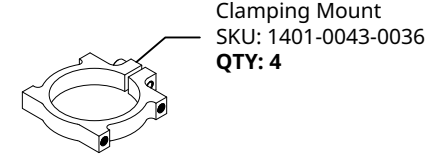
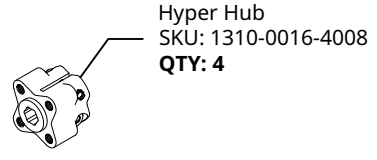
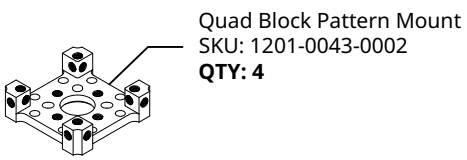

Step 1

Slide a Clamping Mount onto a Gear Motor's gearbox, stop it just short of the 2nd set of screws on the gearbox (as shown in Figure B) then tighten the pinch bolt. After that slide a 4mm long spacer onto the motor shaft as far as it will go. Then slide a Hyper Hub up against the spacer and tighten its pinch bolts.

Figure A

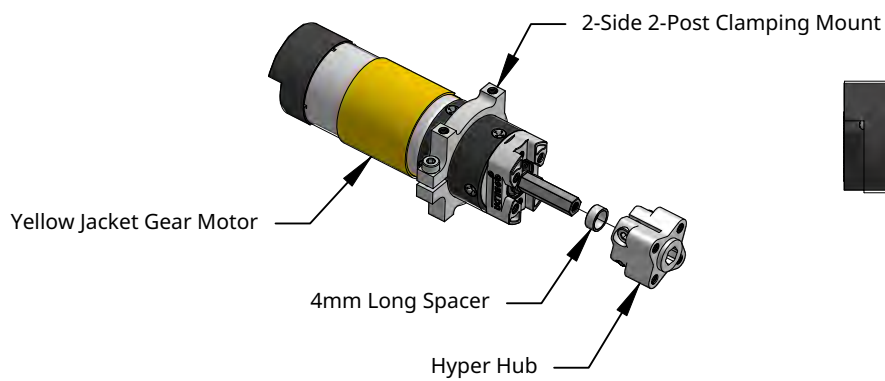
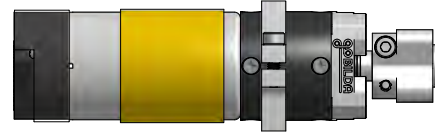
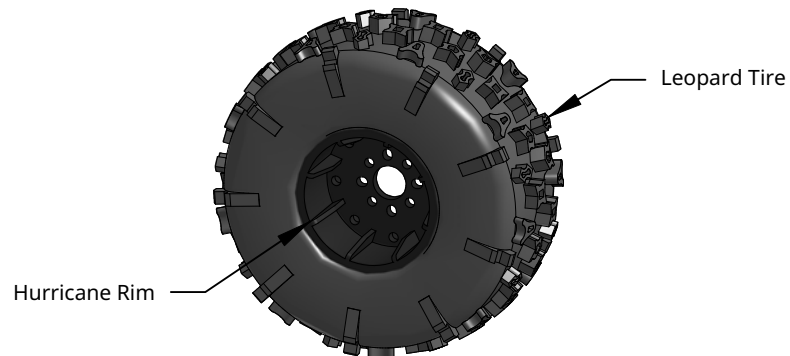

Figure B



Step 2

Using the included Super Glue, glue the Leopard Tire to the Hurricane Rim.



Step 3

Mount the wheel assembly created in step 2 to the Hyper Hub and Motor assembly created in Step 1 using Washers and 12mm Screws.

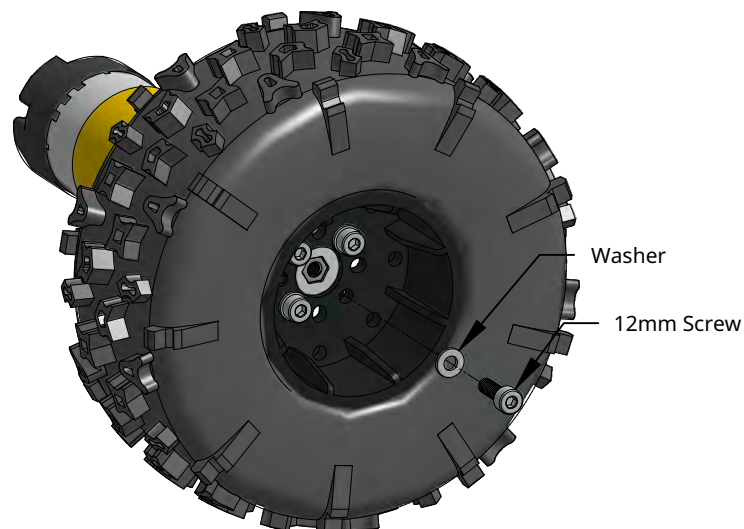

Step 4

Repeat steps 1-3 to create 4 identical subassemblies.

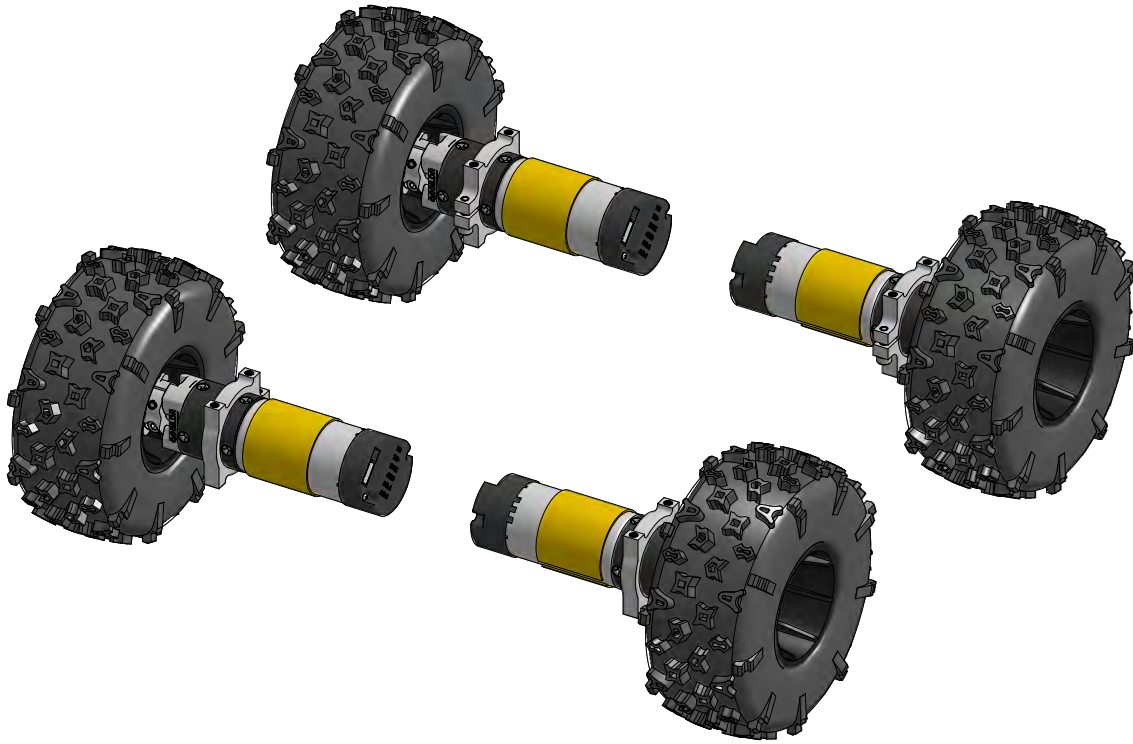

Step 5

Bolt the 4 assemblies you made to the ABS Bottom Panel using 12mm Screws and Washers.

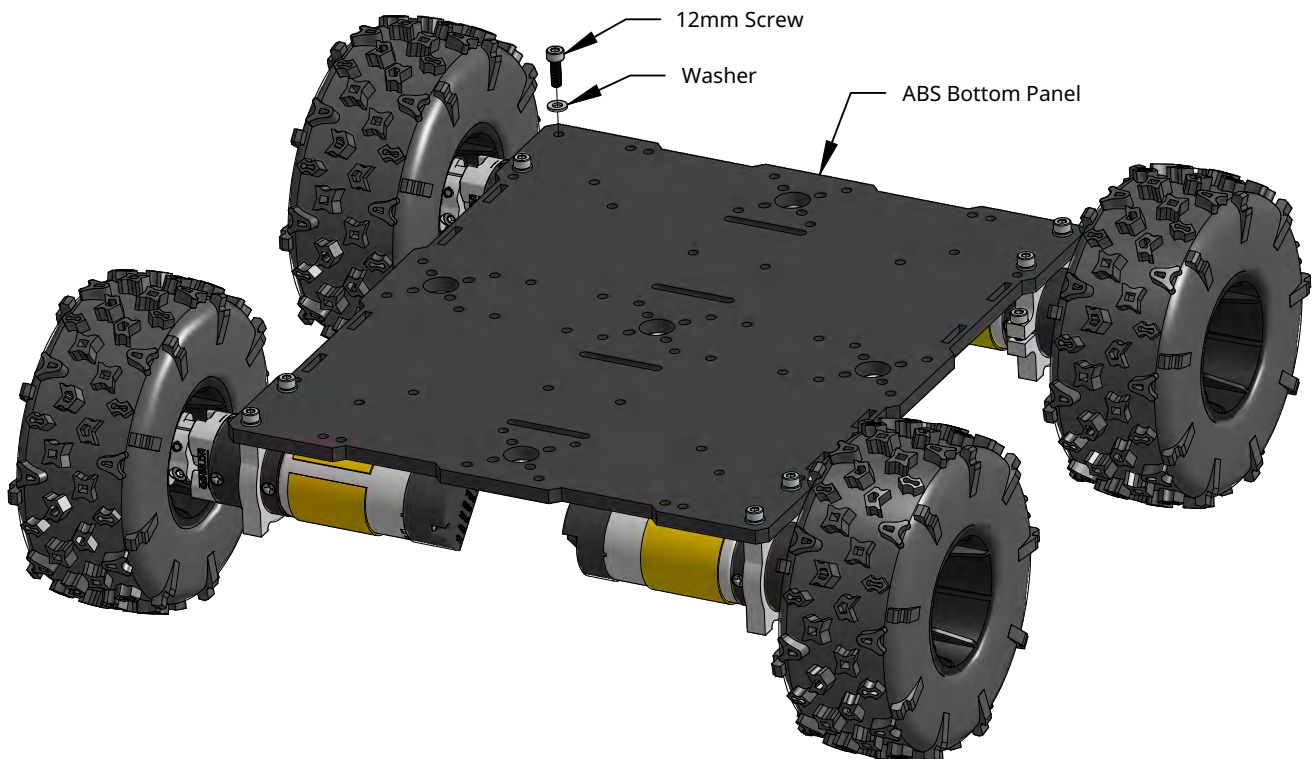

Step 6

Attach a Quad Block Pattern Mount to each side of the chassis using 16mm screws and washers. After this step, set aside this subassembly.

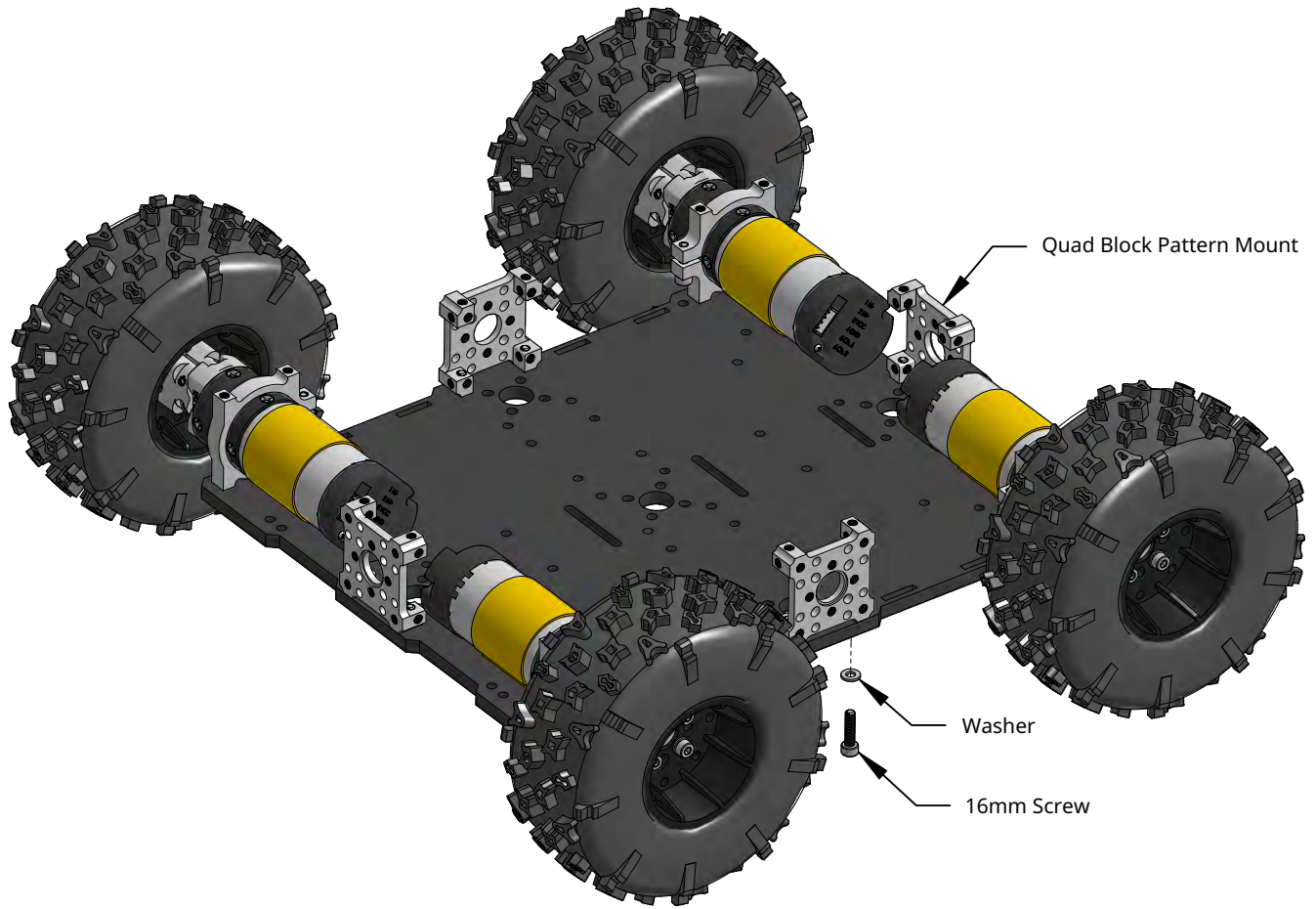

Step 7

Attach the four Door Stops and Door Locks to the ABS Top Panel using 22mm screws, washers, and locknuts. Leave them a little loose, so that the ABS Door Lock can rotate 90°, but with enough resistance to stay in place.

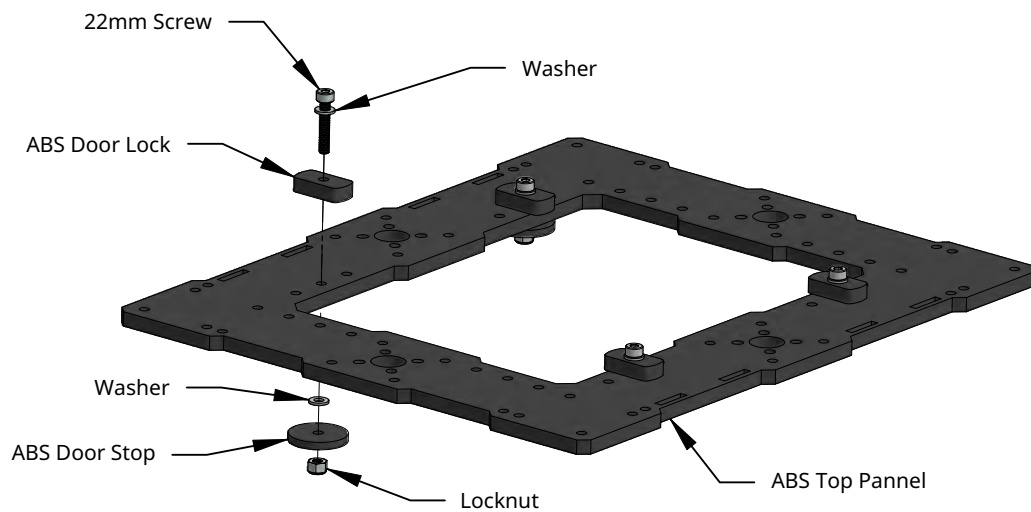

Step 8

Insert the four Side Panels into their slots.

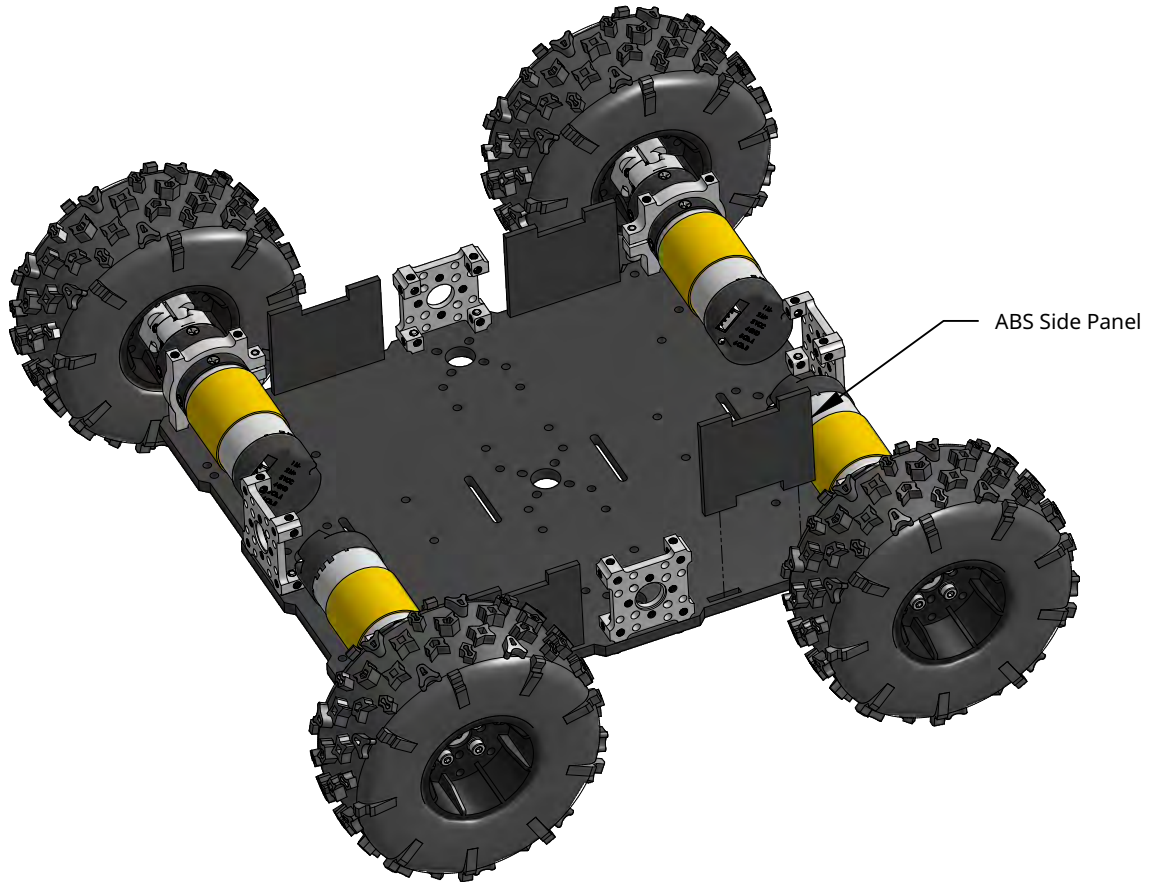

Step 9

Slide the Top Panel Assembly you made earlier into the side panels. Fasten the Top Panel to the Quad Block Mounts using 16mm Screws and Washers.

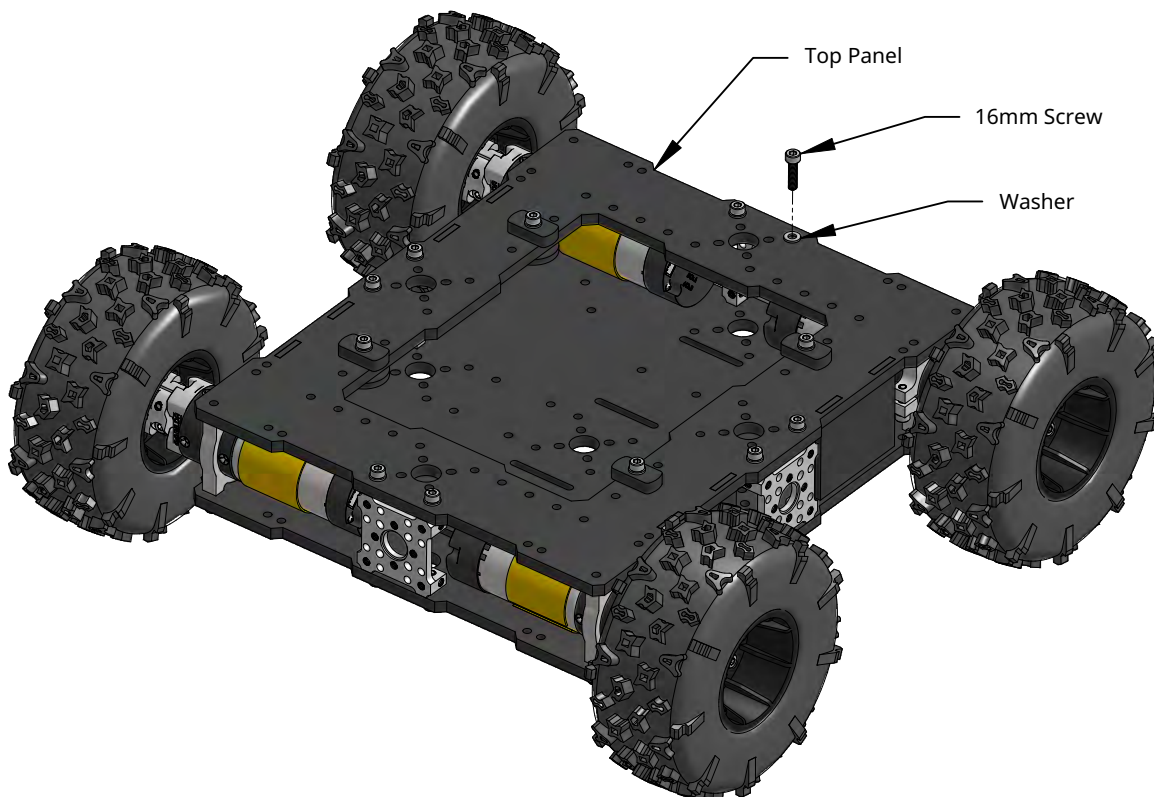

Step 10

Add eight final 12mm screws and washers to the Top Panel affixing the top of each motor's clamping mount.

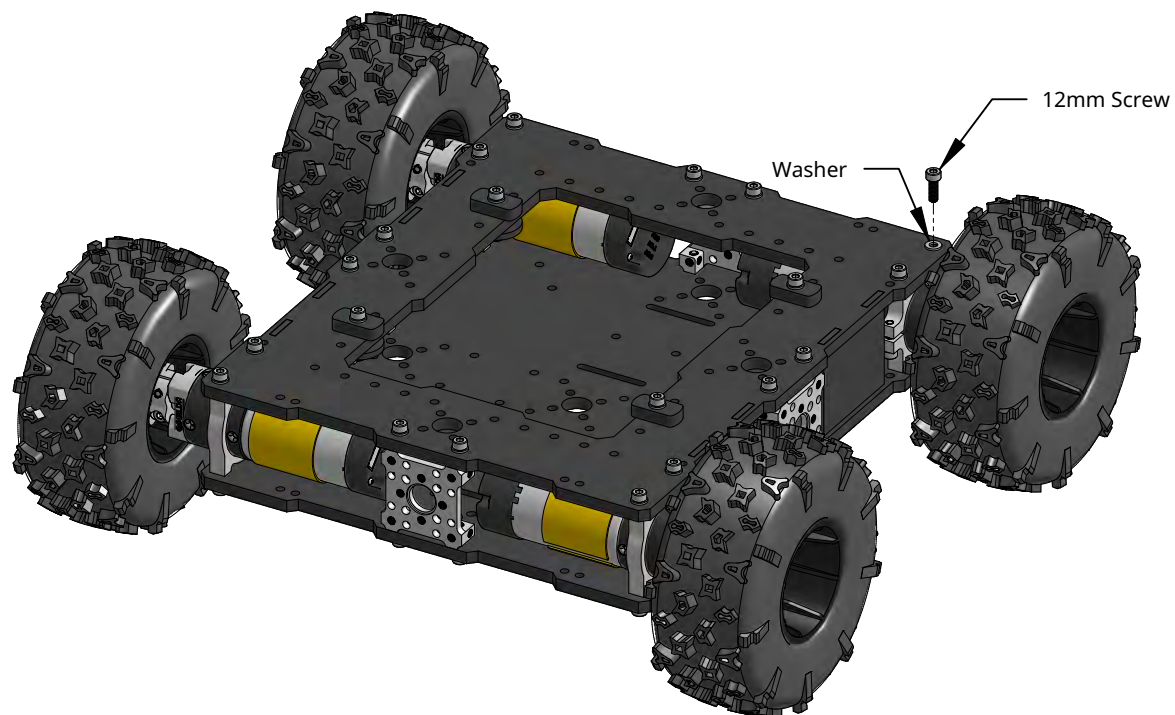

Step 11

Rotate the door lock tabs to the open position. Insert the door and close the lock tabs. **Congratulations, your Recon Chassis is now assembled!**

